

Winstone Gesing Venier Technical Rider

We kindly ask the promoter and/or stage technicians, to prepare the necessary technical items **BEFORE** the arrival of the musicians. This helps to drastically reduce the time necessary for our soundcheck! Thanks in advance ; -)

- 1) **GRAND Piano NOT less than 2,20 m**
perfectly maintained and tuned after soundcheck and before the performance.
A piano appropriate for a classical player!(If possible Steinway)
- 2) **Mics:**
 - Voice: Sure SM58 (preferred)
or Neumann KMS 104 or KMS 105
 - Piano: best available mics
 - Soprano Saxophone / Bass Clarinet:
Klaus Gesing brings his own microphones
 - A) Output of his sound card: 2 regular XLR, balanced, hard panned
 - B) 1 additional XLR, balanced, only used for the piano monitor
- 3) **Monitors:**

Three Way monitoring system, with the possibility of sending effects like reverb separately to the monitors.

Voice: 2 monitors - daisy chained
Piano: 1 Monitor to the right of the piano stool
Soprano/Bcl 2 monitors - stereo image
- 3) **Additionally for Bass Clarinet**
 - A) 1 normal size microphone stand with boom (upper microphone)
 - B) 1 medium size microphone stand with boom (lower microphone)
 - C) Power Supply: 4 Power sockets (Schuko 100-220 Volt)
 - D) 1 very small Microphone stand with boom and a heavy foot
https://www.thomann.de/gb/km_25950.htm
 - E) 2 normal size microphone stands with boom , used as a bass clarinet stand.
- 4) **At least 1 dressing room that is available upon arrival of the musicians in the venue -**

You will make us very happy, if there is tea and coffee, some fruit and chocolate as well as still and sparkling mineral water available in the backstage area. Thank You.

Winstone / Gesing / Venier Stage Plot

Piano

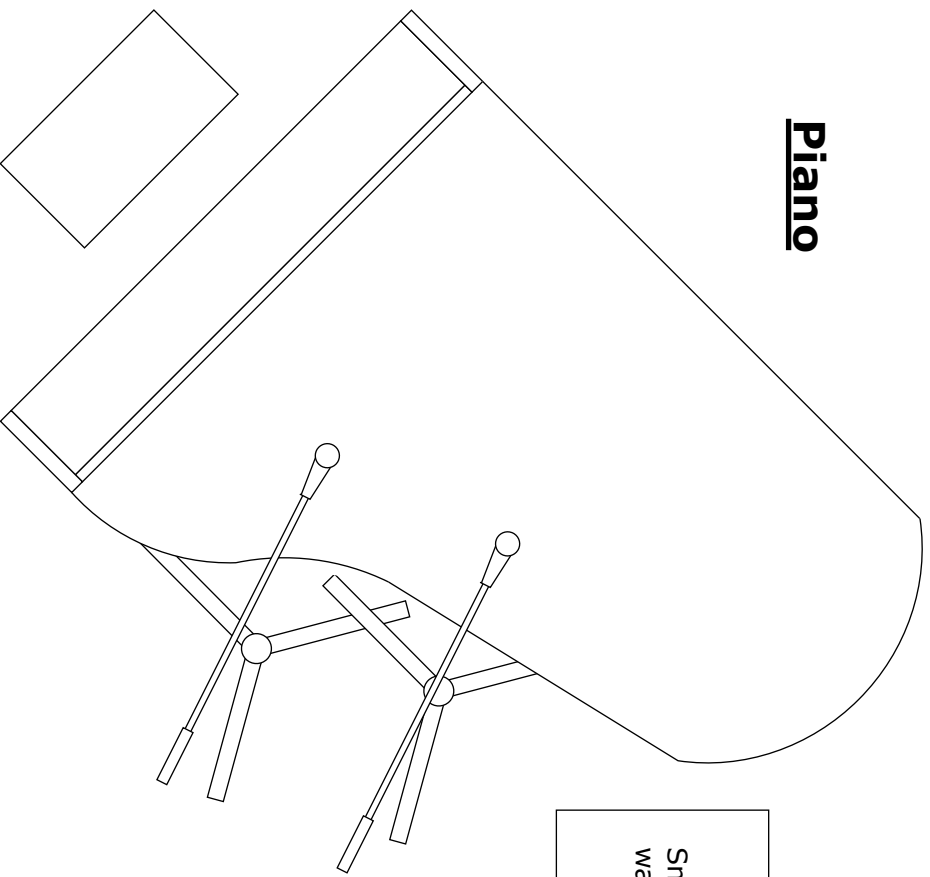

Small table for water (in Glass)

Voice

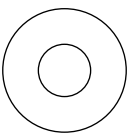

Monitor

Monitor

Monitor

Soprano Sax / Bass Clarinet

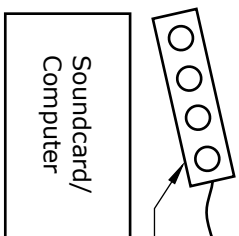

Power Supply (4x Schuko)

Soundcard/
Computer

Very small and heavy mic stand for bass drum, used as rest for bass clarinet while playing

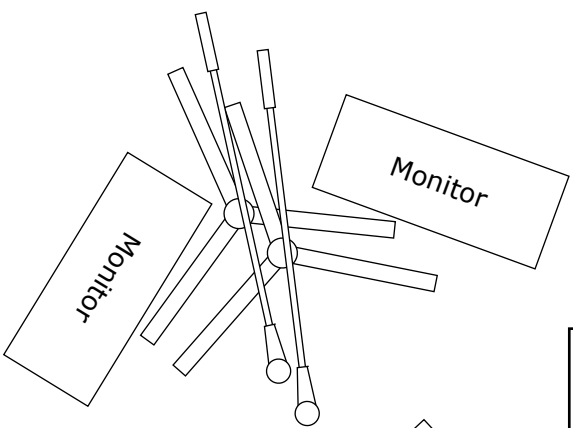

Monitor

2 regular size mic stands with boom - used as bass clarinet stand

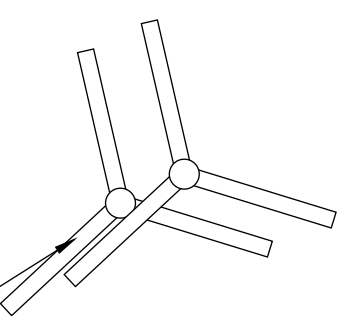

Stage Front